

出厂前请密封机内

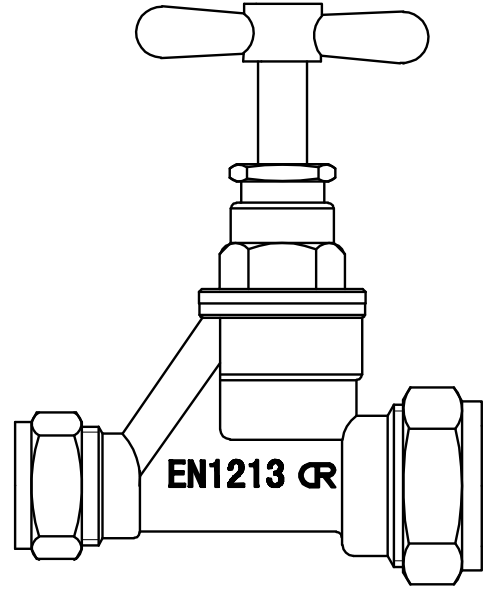
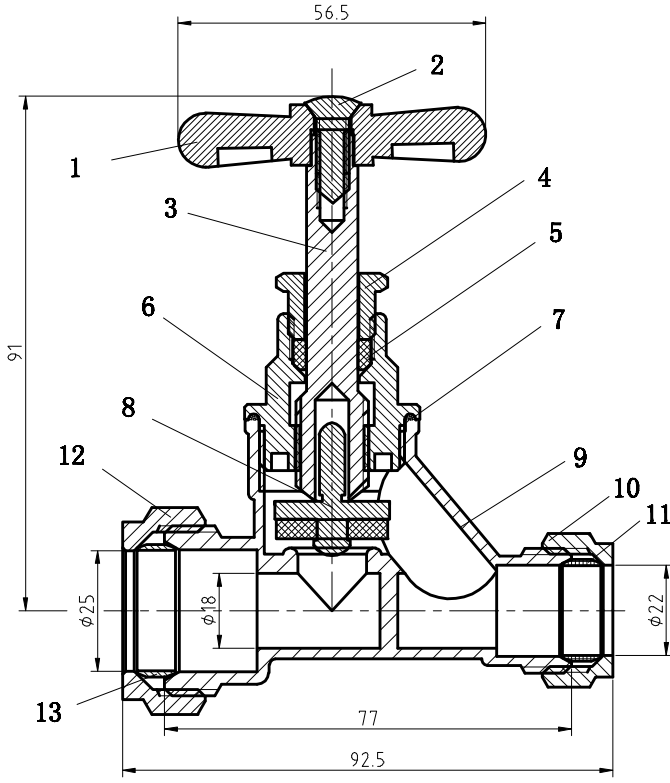

Specification
 Fields of applications: water
 Maximum working pressure: 16bar (0-30°C); 10bar(30-85°C)
 Maximum working temperature: 85°C

发放号		13		Olive	T2	1	
生产	√	12		ComperSSION nut	HPb59-T	1	
打样		11		Olive	T2	1	
试制		10		ComperSSION nut	HPb59-T	1	
状态	A	9		Body	CW602N	1	
		8		Sealing seat	HPb59-T	1	
版次	A	7		Sealing gasket	PTFE	1	
		6		Bonnet	HPb59-T	1	
未注尺寸公差	≥120~400	5		Packing	PTFE	1	
	≥30~120	4		Lock nut	HPb59-T	1	
基本尺寸	≥6~30	3		Stem	HPb59-T	1	
	±0.1	2		Screw	HPb59-T	1	
公差	±0.3	1		Handle	HPb59-T	1	
	±0.5	ITEM	NO.	parts name	material	QTY.	
				品名:		<div style="display: flex; justify-content: space-between;"> ▲ 重要尺寸 ▲ 关键尺寸 </div>	
				DZR POLY STOPCOCK 22x25		材料: 重量:	
				设计: Alger 审核: 批准: 归档:		编号: 客户编号: M35222500DZR	
				签名: 日期: 比例: 1:1 公差等级: IT14 幅面: A4 总1页 第1页		艾迪西流体控制股份有限公司 IDC Fluid Control Co LTD	