

出厂前请密封勿携出

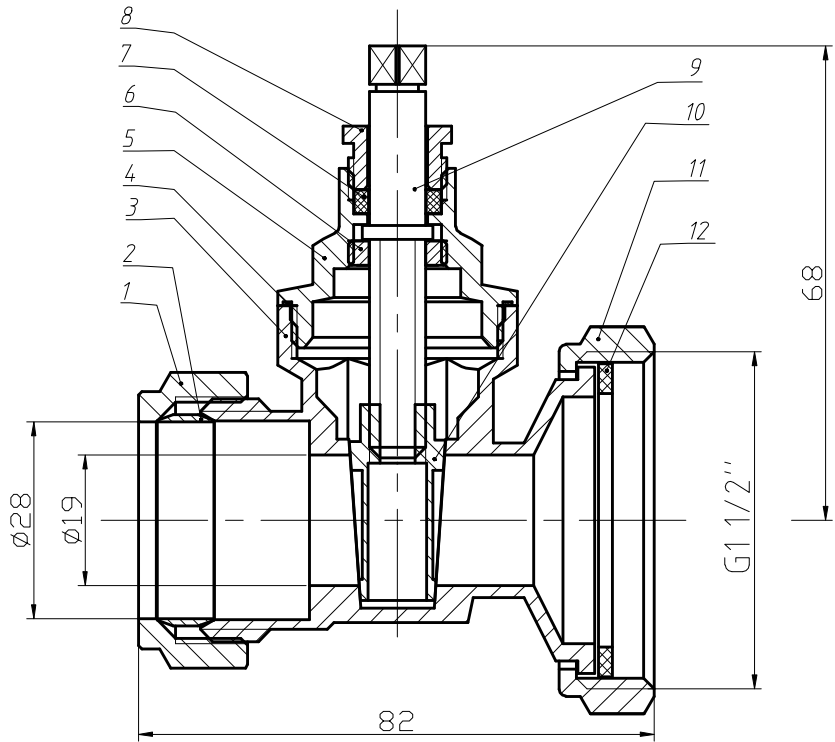

Specification
 Fields of applications: water;
 Maximum working pressure: PN16;
 Operating temperature range: -10 ~ +90°C;
 Compression connections comply with EN1254-2;
 Female thread connections are to ISO228;
 WRAS approved

版次	A	0	12	Gasket	Red paper	1
修改			11	Pump Nut	HPb59-T(企)	1
打样			10	Gate	HPb59-T(企)	1
生产	√		9	Stem	HPb59-T(企)	1
发放号			8	Lock nut	HPb59-T(企)	1
			7	Packing	PTFE	1
			6	Lock ring	HPb59-T(企)	1
			5	Bonnet	HPb59-T(企)	1
			4	Sealing washer	PTFE	1
			3	Body	HPb59-T(企)	1
			2	Olive	T2	1
			1	Compression nut	HPb59-T(企)	1

未注尺寸公差	基本尺寸	<6	±0.1																				
		≥6~30	±0.2																				
		≥30~120	±0.3																				
		≥120~400	±0.5																				
<table border="1"> <thead> <tr> <th>ITEM</th> <th>NO.</th> <th>parts name</th> <th>material</th> <th>QTY.</th> </tr> </thead> <tbody> <tr> <td></td> <td></td> <td></td> <td></td> <td></td> </tr> </tbody> </table>				ITEM	NO.	parts name	material	QTY.															
ITEM	NO.	parts name	material	QTY.																			
<table border="1"> <tr> <td>设计</td> <td>Alger</td> <td></td> <td></td> </tr> <tr> <td>校对</td> <td></td> <td>比例</td> <td>1:1</td> </tr> <tr> <td>审核</td> <td></td> <td>公差等级</td> <td>IT14</td> </tr> <tr> <td>批准</td> <td></td> <td>幅面</td> <td>A4</td> </tr> <tr> <td>归档</td> <td></td> <td>总页数</td> <td>第1页</td> </tr> </table>		设计	Alger			校对		比例	1:1	审核		公差等级	IT14	批准		幅面	A4	归档		总页数	第1页	品名: MF 28mm Pump Valve - Gate Type 艾迪西流体控制股份万达阀门有限公司 IDC Fluid Control Co LTD	
设计	Alger																						
校对		比例	1:1																				
审核		公差等级	IT14																				
批准		幅面	A4																				
归档		总页数	第1页																				
<table border="1"> <tr> <td>重要尺寸</td> <td>▲</td> </tr> <tr> <td>关键尺寸</td> <td>▲</td> </tr> <tr> <td>材料:</td> <td>HPb59-T(企)</td> </tr> <tr> <td>重量:</td> <td></td> </tr> </table>		重要尺寸	▲	关键尺寸	▲	材料:	HPb59-T(企)	重量:		编号: 客户编号: MPVG28													
重要尺寸	▲																						
关键尺寸	▲																						
材料:	HPb59-T(企)																						
重量:																							