

出厂内机密请勿携出

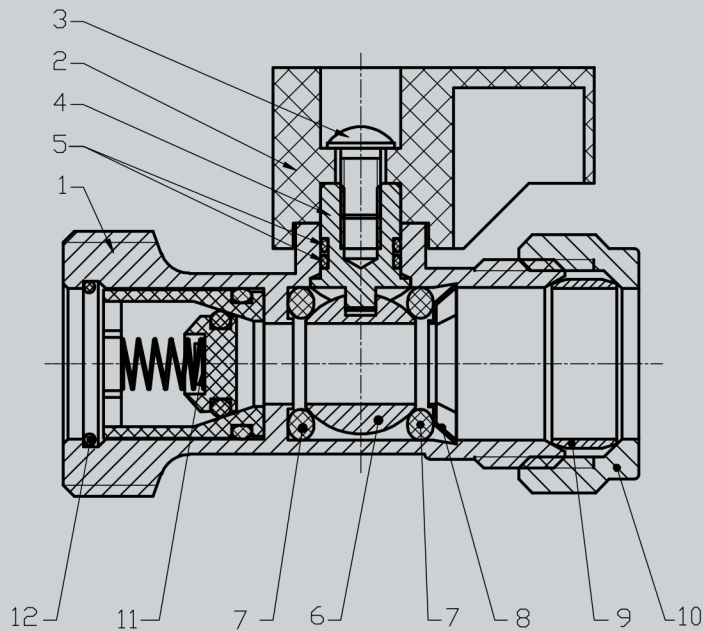

Specification

Fields of applications: water;
 Maximum working pressure: PN10;
 Operating temperature range: -10 ~ +85°C;
 Valves are manufactured to BS6675;
 Compression connections comply with EN1254-2;
 Male thread connections are to ISO228;

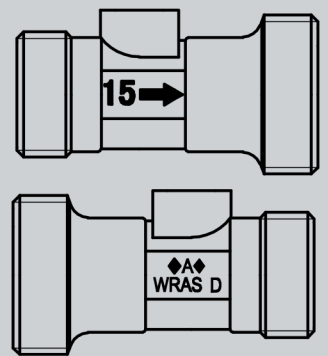

未注尺寸公差

基本尺寸	公差
<6	±0.1
≥6~30	±0.2
≥30~120	±0.3
≥120~400	±0.5

生产	√	12	Catch spring	SS304	1	
打样		11	Check valve	POM	1	
试制		10	Comperssion nut	HPb59-T	1	
		9	Olive	T2 Copper	1	
修改状态	A 0	8	Catch spring	SS304	1	
		7	O-ring	NBR	2	
版本	A	6	Ball	HPb59-T	1	
		5	O-ring	NBR	2	
		4	Stem	HPb59-T	1	
		3	Screw	A3	1	
		2	Handle	ABS	2	
		1	Body	HPb59-T	1	
		ITEM	NO.	parts name	material	QTY.

品名:	15 x 3/4" STR. WASHING MACHINE TAP c/w SCV		
材料:	HPb59-T		
编号:			
客户编号:	MWM1506DCV		
设计	Alger	比例	1:1
审核		公差等级	IT14
批准		幅面	A4
归档		总1页	第1页

重要尺寸
 关键尺寸
 重量:
 艾迪西流体控制股份有限公司
 IDC Fluid Control Co LTD