

出厂前请密封机内

Specification
 Fields of applications: water
 Maximum working pressure: 10bar
 Maximum working temperature: 90℃
 Male thread connection are to ISO228
 The surface is brass color

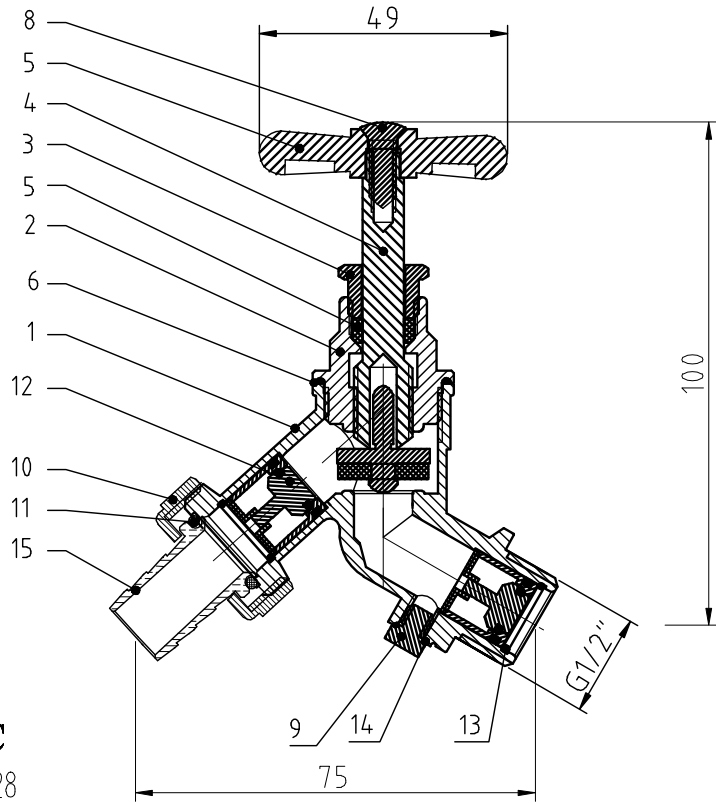

16					
15		Hose Union	HPb59-T	1	
14		O-ring	EPDM	1	
13		Circlip	ICr18Ni9	1	
12	√	Non-return core	POM	2	
11		O-ring	EPDM	1	
10		Nut	HPb59-T	1	
9		Screw	HPb59-T	1	
8		Screw	HPb59-T	1	
7	0	Packing	PTFE	1	
6		Sealing washer	PTFE	1	
5	A	Lock nut	HPb59-T	1	
4		Handle	HPb59-T	1	
3		Stem	HPb59-T	1	
2		Bonnet	HPb59-T	1	
1		Body	CW602N	1	

ITEM	NO.	parts name	material	QTY.
品名: HOSE UNION BIBTAP 1/2 c/w DCV				
材料: DZR				
重量:				
编号:				
客户编号: MBHU04DCV				

未注尺寸公差	≥120~400	±0.5
	≥30~120	±0.3
基本尺寸公差	≥6~30	±0.2
	<6	±0.1

标记处数	更改内容	签名	更改日期
设计	Alger	比例	1:1
审核		公差等级	IT14
批准		幅面	A4
归档		总1页	第1页

艾迪西流体控制股份有限公司
 IDC Fluid Control Co LTD